

**SELF-ACTING TEMPERATURE REGULATORS
TR25/R
(Reverse action for cooling systems)**

DESCRIPTION

The TR25/R valves series are designed for temperature control in cooling systems where the valve opens with temperature rise. They are single seated, unbalanced and intended to be coupled with T series thermostat models T.205 and T.405. The liquid filling the thermostat expands when the temperature of the fluid being cooled rises, opening the valve.

MAIN FEATURES

- Easily adjustable temperature range.
- Proportional temperature control.
- Single seated, two way, reverse acting valve.
- Built-in strainer.
- Narrow thermostat neutral zone (1,5 to 2,5 °C).
- No special tools required for servicing.
- Stuffing box is an integral part of the thermostatic element, allowing easy and simple maintenance of the valve.

- OPTIONS:**
- PK sensor pocket.
 - Different capillary lengths.
 - Other thermostats on request.

- USE:**
- Water, air and other gases and liquids compatible with the construction.

- AVAILABLE VALVES:**
- TR25S/R – carbon steel.
 - TR25i/R – stainless steel.

- AVAILABLE THERMOSTATS:**
- T.205 – 400 N (max. closing force).
 - T.405 – 500 N (max. closing force).

- SIZES:**
- 1/2" to 1"; DN 15 to DN 25.

- CONNECTIONS:**
- Female threaded ISO 7 Rp.
 - Flanged EN 1092-1 PN 40.

- THERMOSTAT RANGES:**
- T.205: 0 to 60 °C, 30 to 90 °C and 60 to 120 °C.
 - T.405: 0 to 120 °C and 40 to 160 °C.

- INSTALLATION:**
- Horizontal installation with the thermostat in the vertical position, in order to reduce wear.
 - A "Y" strainer should be installed upstream of the valve.
 - See IMI – Installation and maintenance instructions.

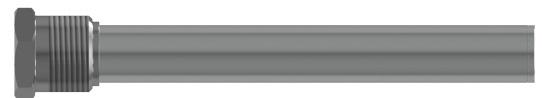
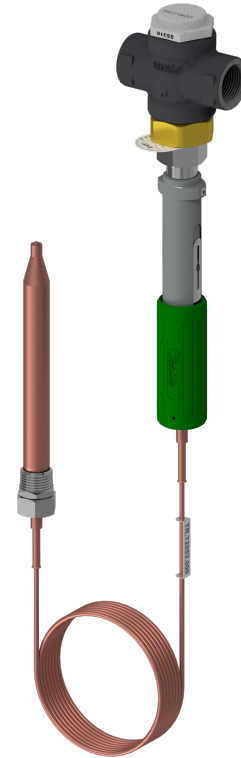

PK sensor pocket

BODY LIMITING CONDITIONS	
PN 40 ALLOWABLE PRESSURE	RELATED TEMPERATURE
40 bar	120 °C
24 bar	350 °C

Minimum operating temperature: -10 °C.
Maximum operating temperature: 150 °C.

TR25 – T SERIES THERMOSTATS – FTO, UNBALANCED TRIM, METAL SEALING (CLASS IV)						
TYPE	SIZE	SEAT Ø	Kvs (m³/h)	STROKE	MAX. PERMISSIBLE PRESSURE DROP	
					T.205	T.405
TR25 – 15/15	1/2" – DN 15	15 mm	1,9	6 mm	15 bar	20 bar
TR25 – 20/15	3/4" – DN 20	15 mm	1,9	6,5 mm	15 bar	20 bar
TR25 – 20/20	3/4" – DN 20	20 mm	4,2	6,5 mm	9 bar	12 bar
TR25 – 25/20	1" – DN 25	20 mm	4,2	7 mm	9 bar	12 bar

PROPORTIONAL BAND

The proportional band is the temperature change required for the valve to move from its fully open to fully closed position. It depends on the valve stroke (mm) and on the thermostat movement per °C (mm/°C), and is calculated as follows:

$$\text{Proportional band} = \frac{\text{Valve stroke (mm)}}{\text{Thermostat movement (mm/°C)}}$$

Thermostat movement for T.205 and T.405: 0,5 mm/°C.

A proportional band between 8 °C and 13 °C is suitable for most applications. A smaller proportional band is not ideal when heat loads vary rapidly.

DIMENSIONS – THERMOSTAT (mm)					
TYPE	A	B	C	ØE	WEIGHT (kg)
T.205	305	405	210	22	1,8
T.405	385	525	390	22	2,6

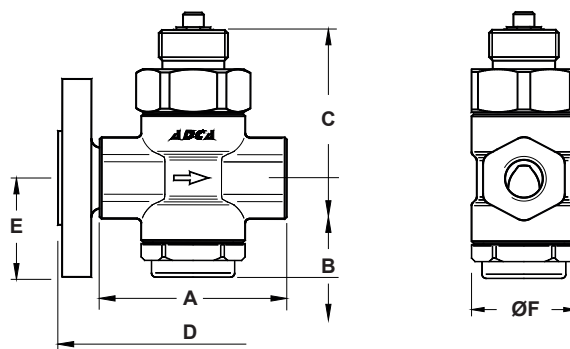
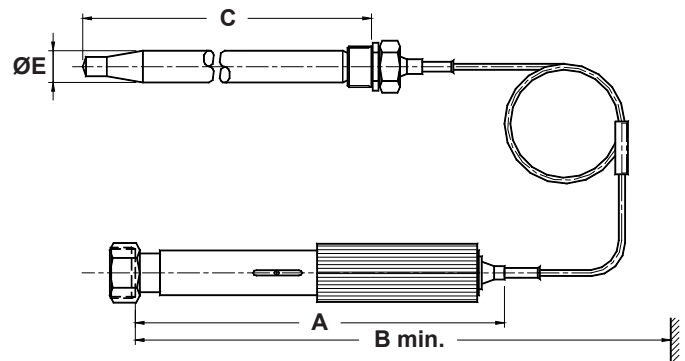

DIMENSIONS – VALVE BODY (mm)								
SIZE	THREADED					PN 40		
	A	B	C	ØF	WEIGHT (kg)	D	E	WEIGHT (kg)
1/2" – DN 15	90	40	70	50	1,2	130	47,5	2,6
3/4" – DN 20	90	40	70	50	1,2	150	52,5	3,2
* 3/4" – DN 20	100	45	75	55	1,6	150	52,5	3,6
1" – DN 25	100	45	75	55	1,6	160	57,5	4,2

* TR25 – 20/20 model only.

MATERIALS			
POS. N°	DESIGNATION	TR25S/R	TR25I/R
1	Body	P250GH / 1.0460	AISI 316 / 1.4401
2	Bonnet	C45E / 1.1191	AISI 316L / 1.4404; AISI 303 / 1.4305
3	* Gasket	St. steel / Graphite	St. steel / Graphite
4	* Valve plug	St. steel / EPDM	St. steel / EPDM
5	Seat	AISI 316 / 1.4401	AISI 316 / 1.4401
6	* Spring	AISI 302 / 1.4300	AISI 302 / 1.4300
7	Cap	AISI 316 / 1.4401	AISI 316 / 1.4401
8	* Cap gasket	St. steel / Graphite	St. steel / Graphite

* Available spare parts.

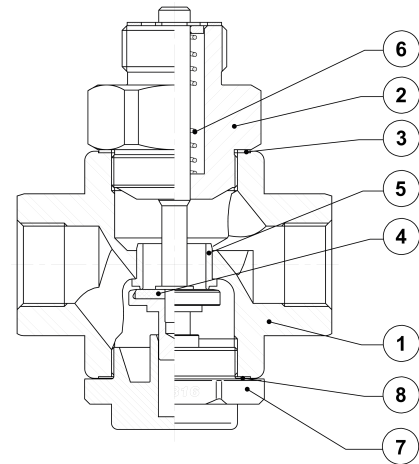

PK SENSOR POCKETS

Sensor pockets made of stainless steel can be supplied with all TR series self-acting thermostats using rod sensors. A sensor pocket, also called thermowell, is used to protect the sensor and to allow its removal while the plant is running or, e.g., the tank where it is connected to is full. The use of sensor pockets implies delay of heat transfer to the rod sensors and, thus, a longer thermostat reaction time. This is, to some extent, counteracted by filling up the sensor pockets with a thermal conductive paste or glycerine.

INSTALLATION

The installation site for the sensor pocket is arbitrary when paste is applied. When glycerine is used, the sensor pocket must point at least slightly downwards.

MATERIAL

AISI 316 / 1.4401.

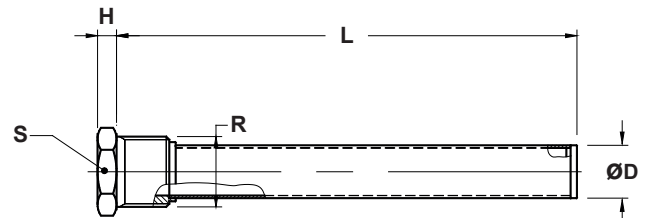

DIMENSIONS (mm)					
TYPE	ØD	H	L	S	R
PK2	25	9	218	36	1"
PK4	25	10	390	45	1 1/4"